

Installation Guide

This procedure is designed as an installation aid. Skilled tradespeople that are familiar with general construction and electrical installation techniques should perform the installation. Licensed electricians should provide electrical installation connections. Installations and connections should be done in accordance with all national and local codes and permits. In no way is this document intended to construe warranty or fitness of use of the products described, nor is it intended to provide safety instruction for those installing the product.

⚡ WARNING

Before proceeding with installation or service maintenance of this product:

- Disconnect power to reduce electrical shock risk.
- Review the entire Installation Guide.
- Inspect this properly packaged product for any damage that may have occurred during transit.
- Verify product application complies with manufacturer design recommendations.
- Verify the availability of necessary tools and incidental material.
- Verify applicable code requirements. Field assembly and installation are subject to acceptance by local inspection authority.
- Appropriate safety equipment to be determined by end user, per applicable safety standards and precautions.

Bracket Trunnion installation method

-Installation Tools Reference - Packing List:

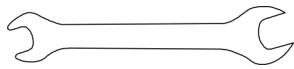

10mm inner
Open wrench

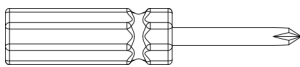

cross
screwdriver

Note: Installation tool is not included with product.

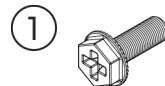
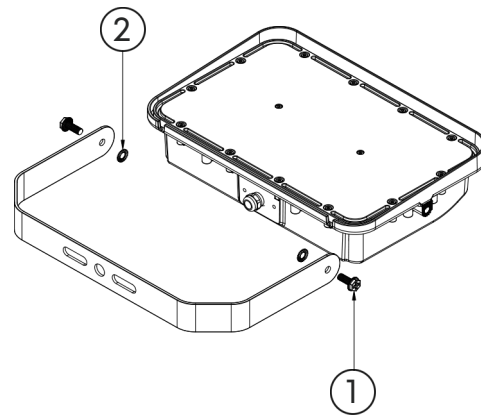

M6*16mm 2PCS



M6mm 2PCS

A

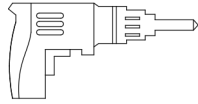

Step 1 - Play two holes in the wall or ceiling ,open hole size as shown in Figure E .

B

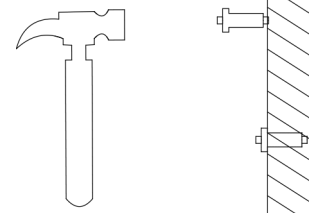

Step 2 - Push the expansion screw into the wall or ceiling.

C

Torque force $\geq 8.3\text{N}\cdot\text{m}$ until locking

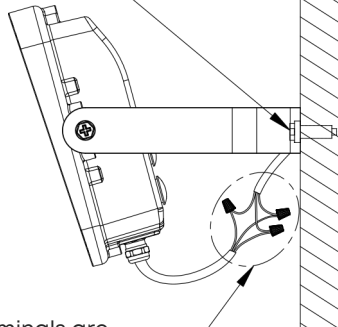

Note: The wiring terminals are waterproof with glue or connected with waterproof connectors.

Step 3 - Connect the cable in the holder to the municipal wire, as shown in Figure F.

D

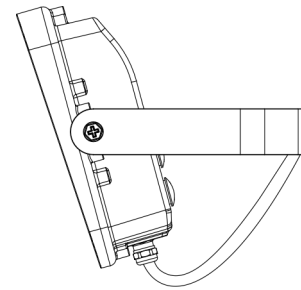

Step 4 - Fix the fixture on the wall or ceiling and adjust the angle.

E

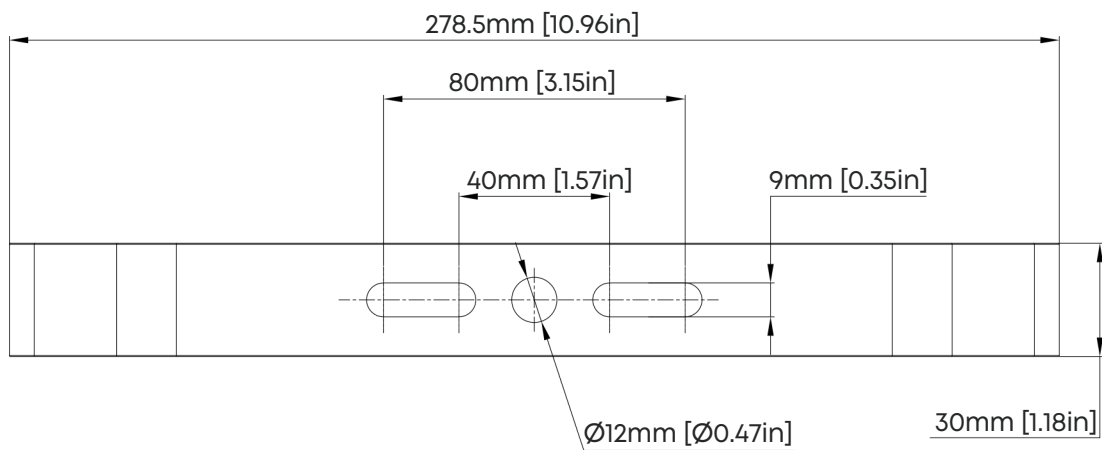

F Knuckle with junction box

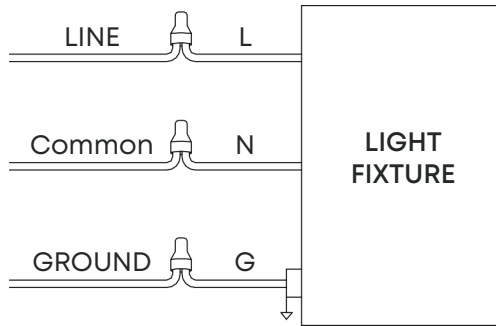

G

1. Adjust the color temperature and power according to the following instructions and loosen the waterproof plug fixture, as shown in Figure 3.
Power factory Settings: On/off option.
Color temperature Factory setting: 4000K (CCT).
2. Select the power gear by toggling the DIP switch, as shown in Figure 4.
The initial power is reduced by 10% per gear for a total of 4 gears.
(For example, the initial power 60W is adjustable: 54W, 50W, 45W, 41W).
3. Select the color temperature (CCT) by flicking the dip switch, as shown in Figure 5.
Color temperature DIP switch: First gear :3000K; second gear :4000K and third gear :5000K.
4. Reinstall the waterproof plug and tighten it.

