

Installation Guide

This procedure is designed as an installation aid. Skilled tradespeople that are familiar with general construction and electrical installation techniques should perform the installation. Licensed electricians should provide electrical installation connections. Installations and connections should be done in accordance with all national and local codes and permits. In no way is this document intended to construe warranty or fitness of use of the products described, nor is it intended to provide safety instruction for those installing the product.

⚡ WARNING

Before proceeding with installation or service maintenance of this product:

- Disconnect power to reduce electrical shock risk.
- Review the entire Installation Guide.
- Inspect this properly packaged product for any damage that may have occurred during transit.
- Verify product application complies with manufacturer design recommendations.
- Verify the availability of necessary tools and incidental material.
- Verify applicable code requirements. Field assembly and installation are subject to acceptance by local inspection authority.
- Appropriate safety equipment to be determined by end user, per applicable safety standards and precautions.

Bracket B installation method

-Installation Tools Reference - Packing List:



14mm inner
hexagon wrench



6mm inner
hexagon wrench

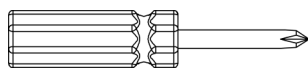

Cross screwdriver

Note: Installation tool is not included with product.

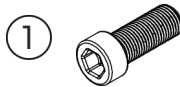
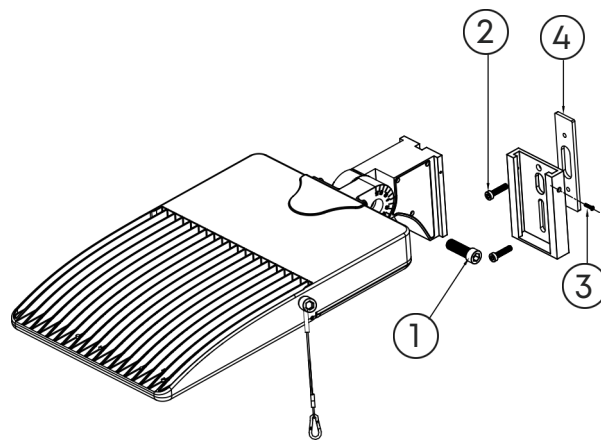

① M16*50mm 1PCS



② M8*35mm 2PCS



③ M4*12mm 2PCS



④ E Stamping sheets
1PCS

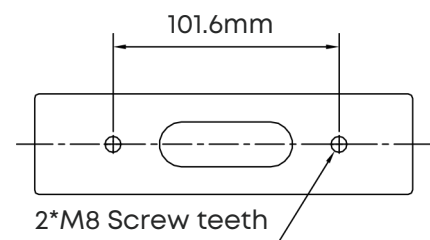

A

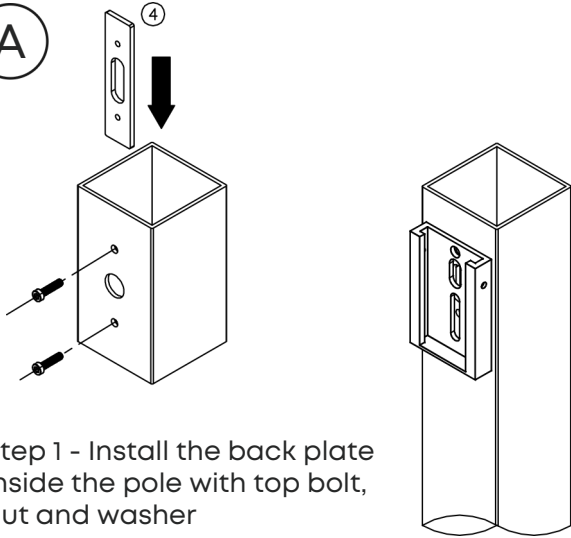

Step 1 - Install the back plate inside the pole with top bolt, nut and washer

B

Torque force $\geq 8.5\text{N}\cdot\text{m}$ until locking

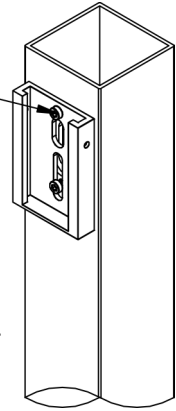

Step 2 - Install the adapter bracket

C

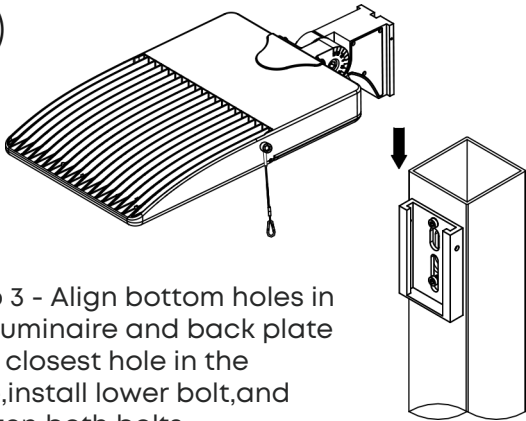

Step 3 - Align bottom holes in the luminaire and back plate with closest hole in the pole, install lower bolt, and tighten both bolts

D

Torque force $\geq 5\text{N}\cdot\text{m}$ until locking

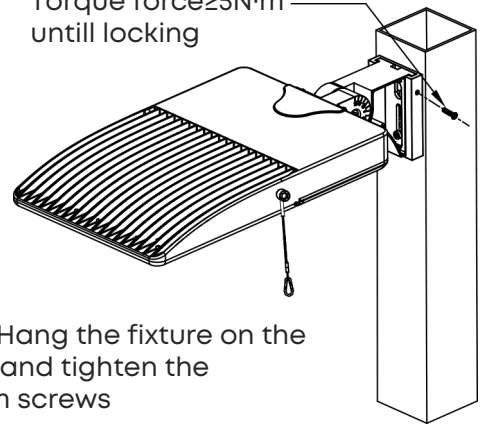

Step 4 - Hang the fixture on the bracket and tighten the M4*12mm screws

E

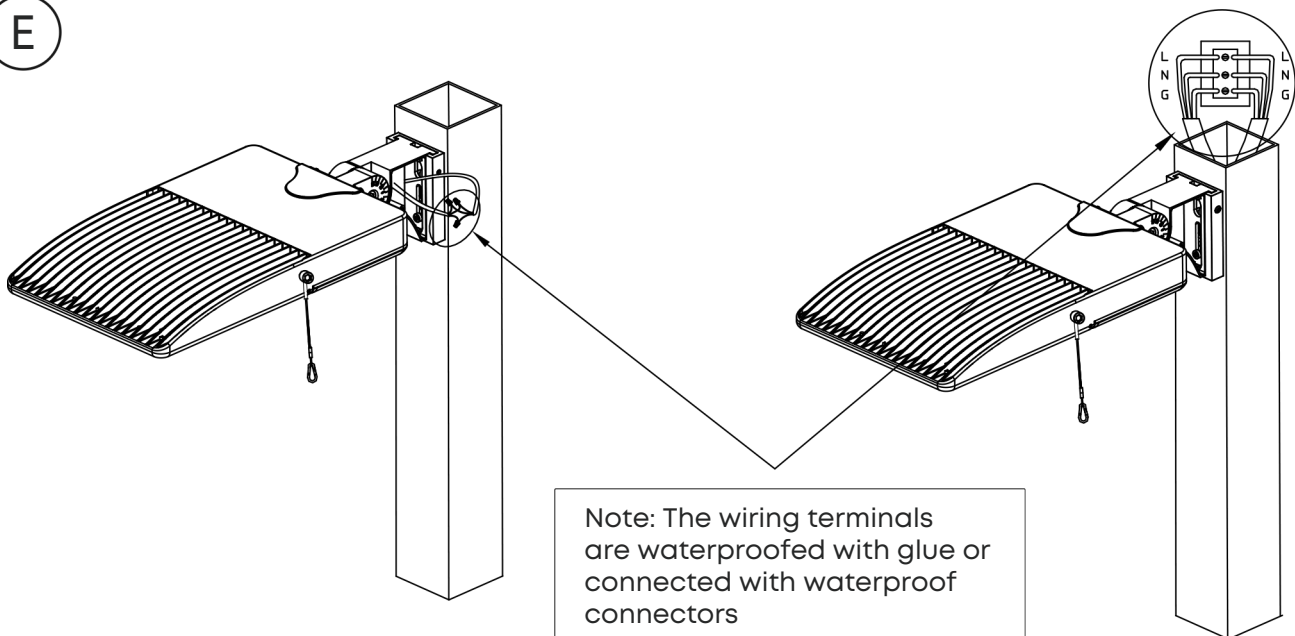

Note: The wiring terminals are waterproofed with glue or connected with waterproof connectors

Step 5 - Connect the cable in the B holder to the municipal wire, as shown in Figure G or H

F

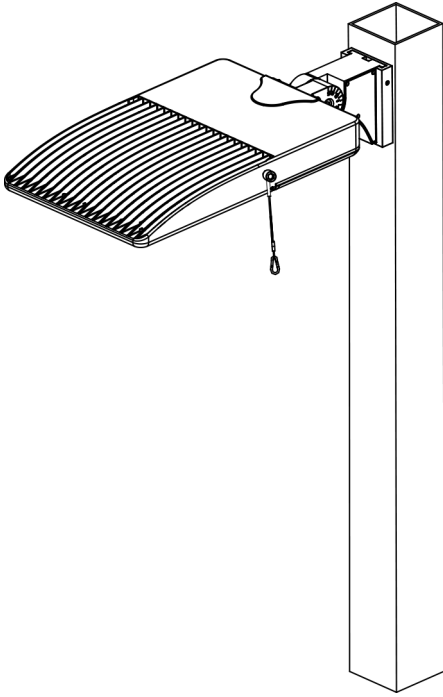

Step 6 - Tighten the cover screws and do a good waterproof treatment

G

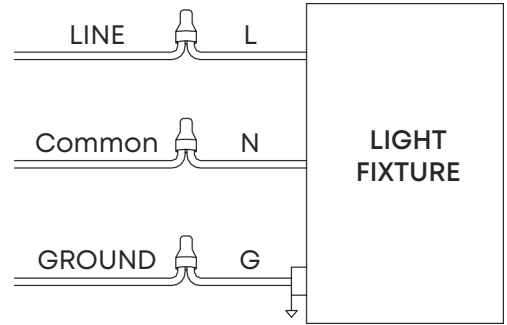

H

0-10V Dim Wiring

