

Installation Guide

This procedure is designed as an installation aid. Skilled tradespeople that are familiar with general construction and electrical installation techniques should perform the installation. Licensed electricians should provide electrical installation connections. Installations and connections should be done in accordance with all national and local codes and permits. In no way is this document intended to construe warranty or fitness of use of the products described, nor is it intended to provide safety instruction for those installing the product.

⚡ WARNING

Before proceeding with installation or service maintenance of this product:

- Disconnect power to reduce electrical shock risk.
- Review the entire Installation Guide.
- Inspect this properly packaged product for any damage that may have occurred during transit.
- Verify product application complies with manufacturer design recommendations.
- Verify the availability of necessary tools and incidental material.
- Verify applicable code requirements. Field assembly and installation are subject to acceptance by local inspection authority.
- Appropriate safety equipment to be determined by end user, per applicable safety standards and precautions.

Product Parts Include Introduction

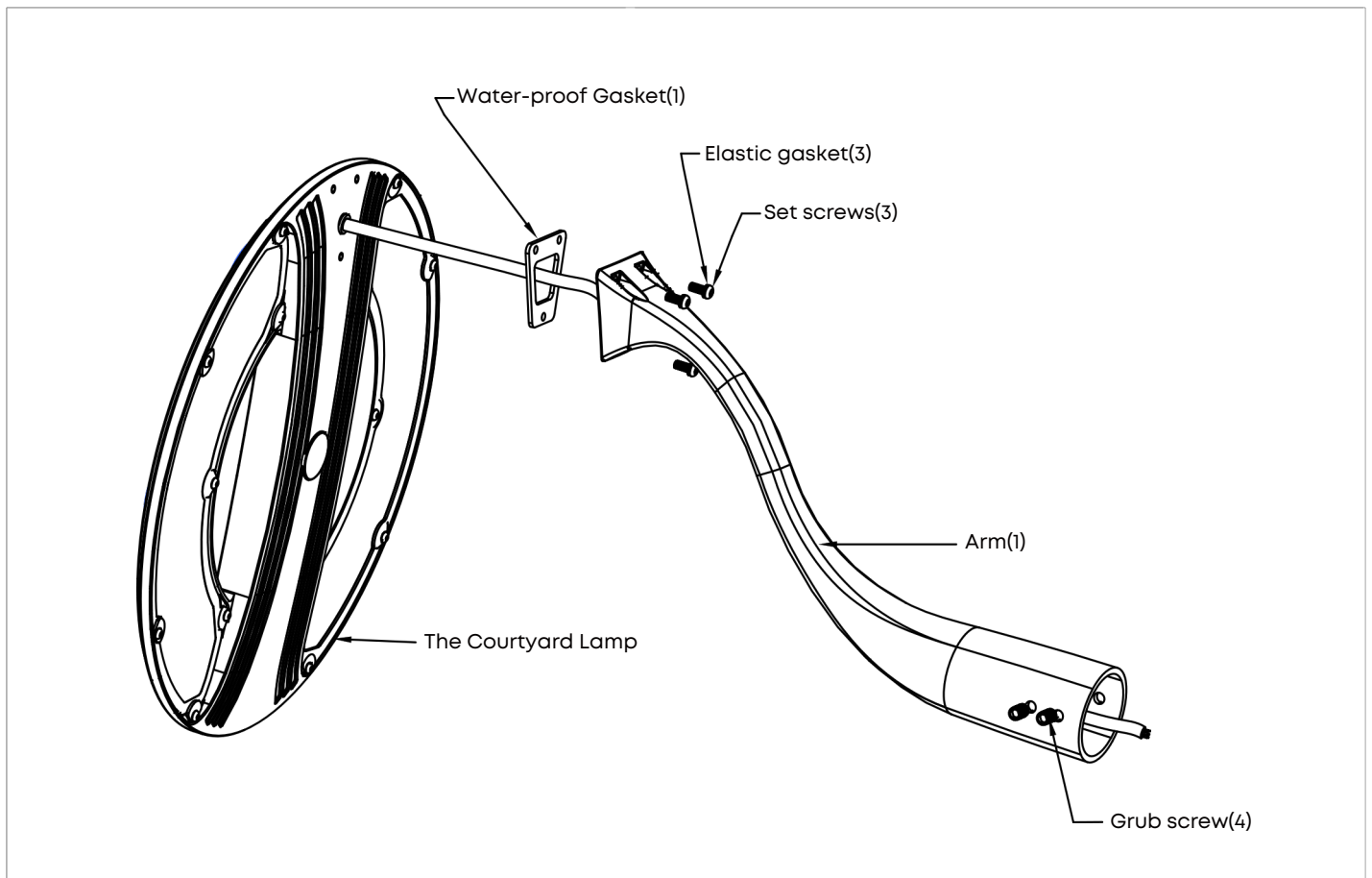

Installation Guide

Preparation for installation of the courtyard lamp

Step 1: Place the waterproof gasket in the groove position of the lamp arm.

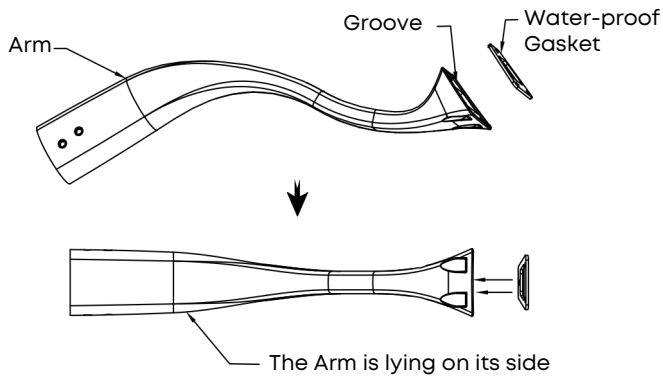

Step 2: Put the wire through the arm.

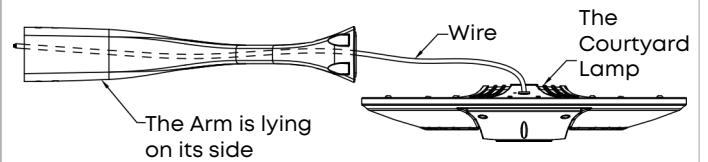

Step 3: Align the hole of bent arm with the lamp body's screw position.

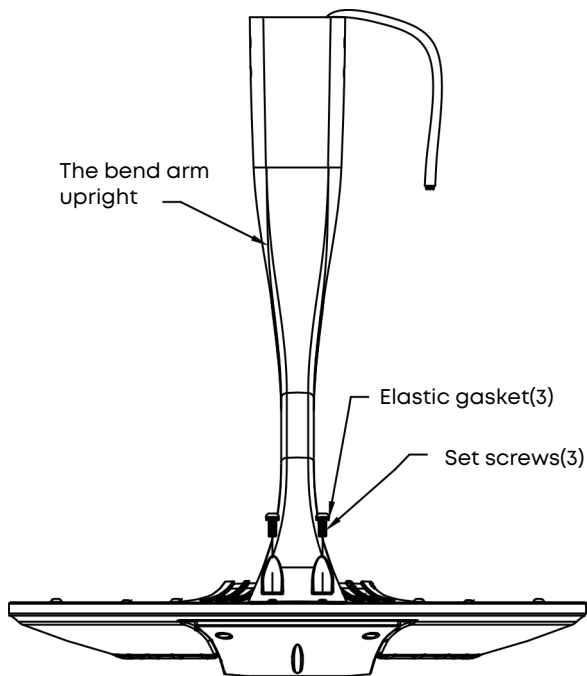

Step 4: Tighten the fixing screw with an inner hexagon wrench. The torsion:13-17 N*m.

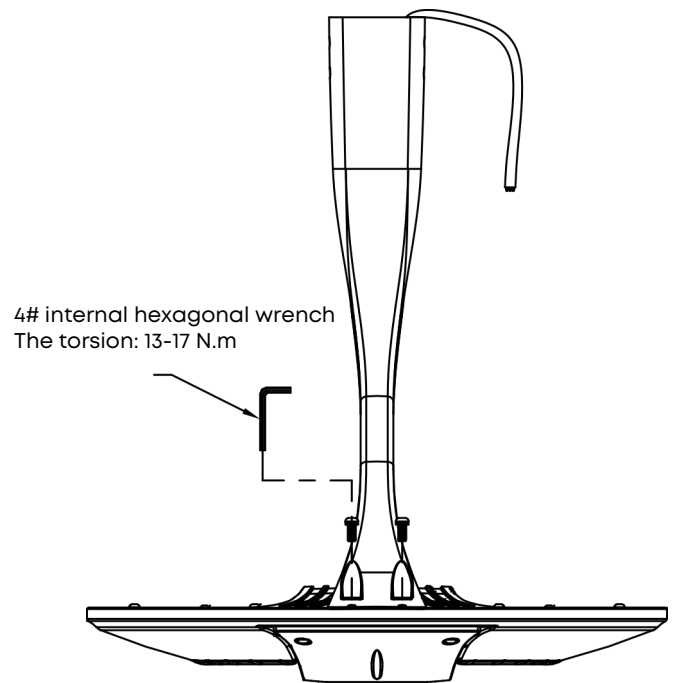

Installation Guide

Preparation for installation of the courtyard lamp

Step 5: Thread the wire out of the light pole.

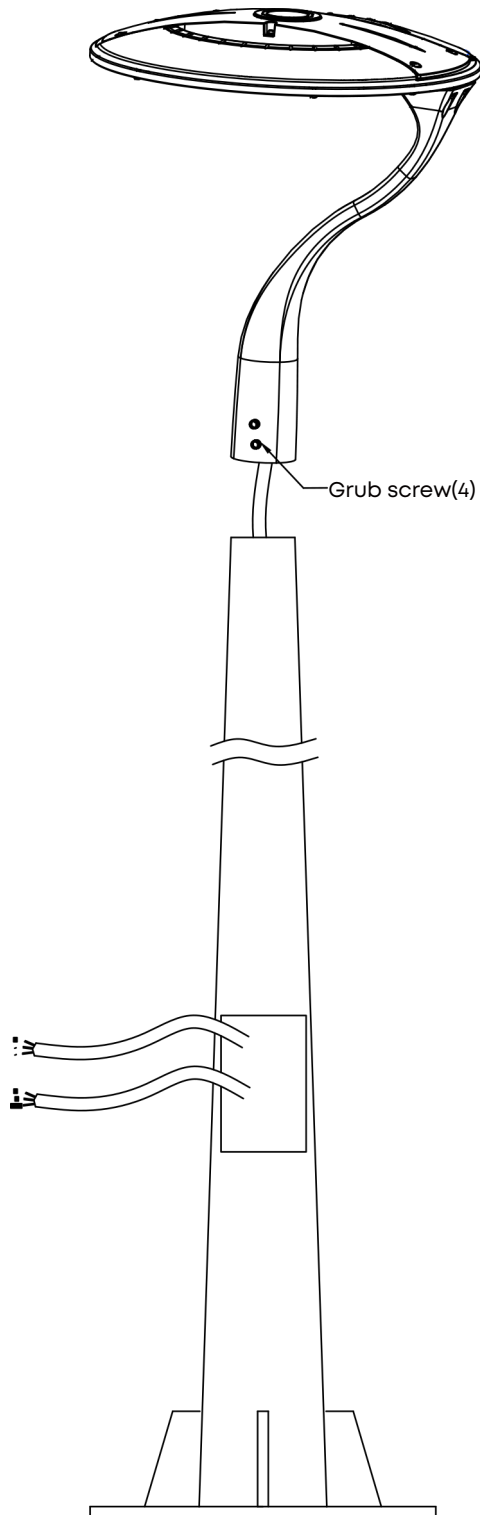

Step 6: Insert the elbow of the lamp into the lamp post and tighten 6 fixing screws with an inner hexagonal wrench.
The torsion: 19-22 N*m.

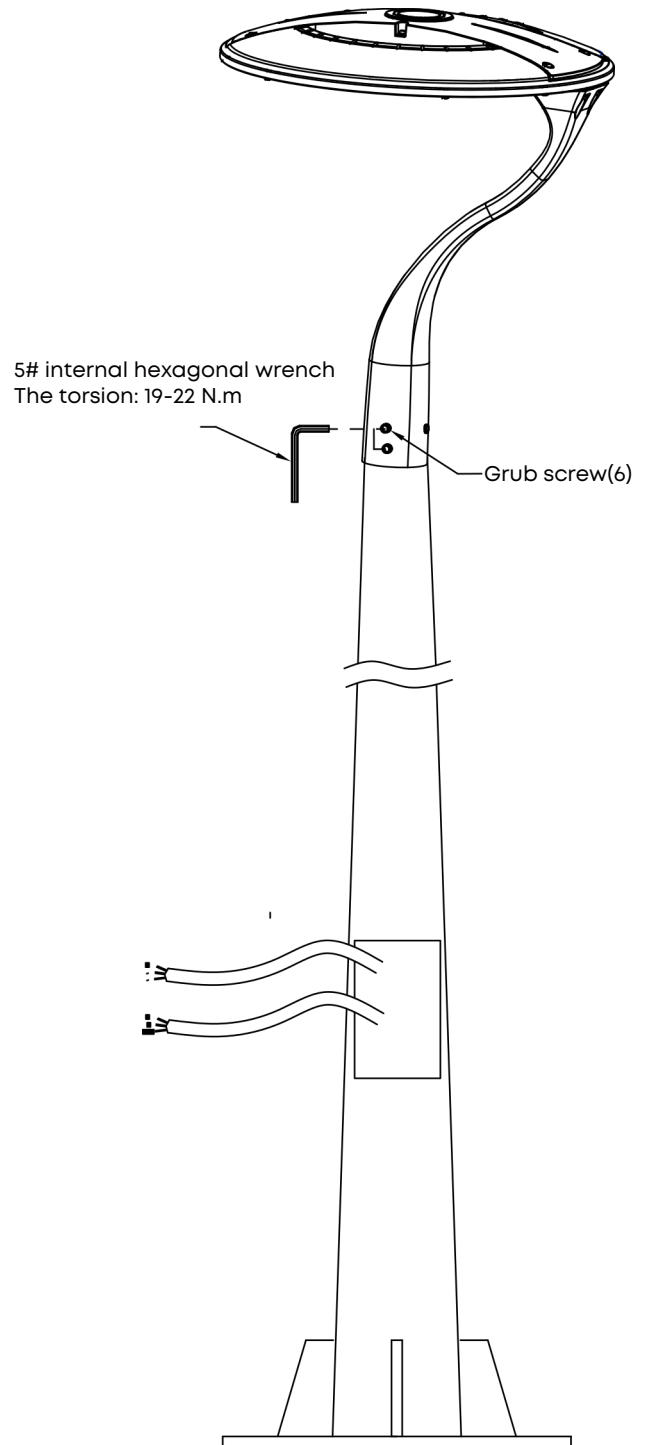

Installation Guide

Preparation for installation of the courtyard lamp

Step 7: Connect the wires on the lamp to the V+,V1-,V2- on the power supply out of the power box. Connect the L,N,GND on the power input end of the power box out of the light pole install the electric box on the light pole and fix it, and put a circle of waterproof glue around the contact surface of the electric pole and the electric box.

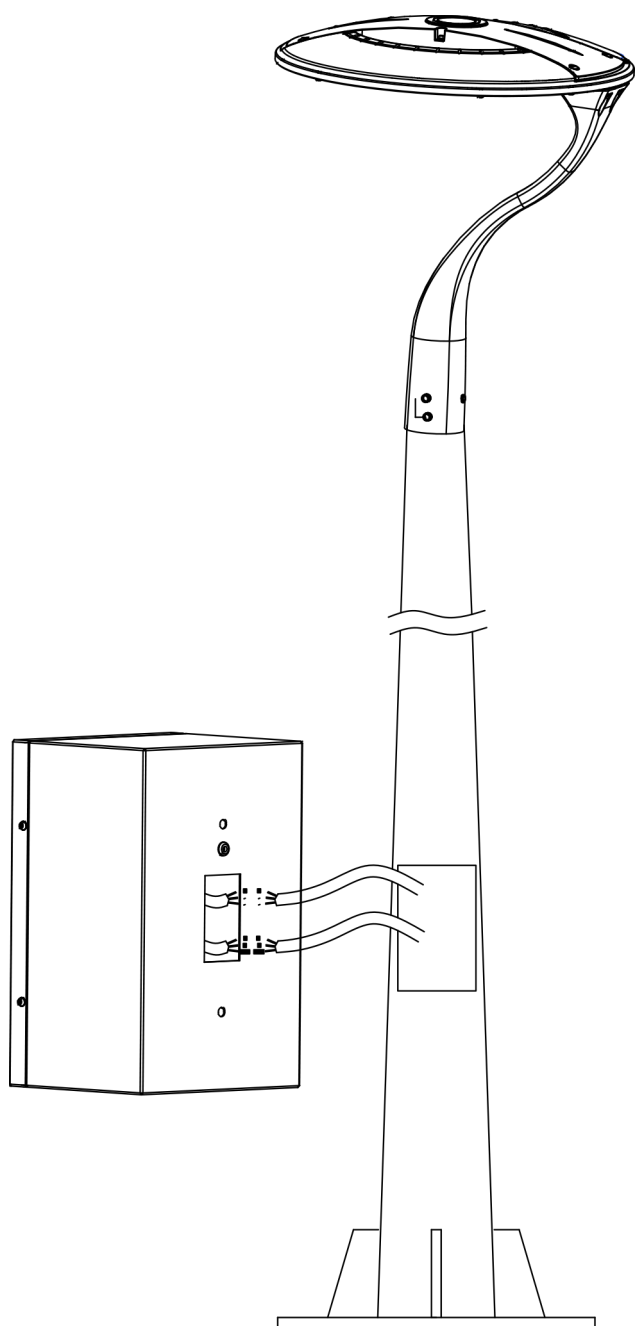

Step 8: Installation is complete

